

15 GHz actively mode-locked fiber laser at 2 micron

Jiarong Qin, Ruihong Dai, Yafei Meng, Wenbin Gao, Yongbing Xu, Yao Li*, Shining Zhu, Fengqiu Wang*

School of Electronic Science and Engineering, Nanjing University, Nanjing 210093, China

Email: liyao@nju.edu.cn, fwang@nju.edu.cn

Abstract: We demonstrate a 15-GHz actively-mode-locked thulium fiber laser. The repetition-rate is improved by one order of magnitude compared with existing results and such a source can be used for 2 μm optical data-communication and processing.

OCIS codes: (060.3510) Lasers, fiber; (140.3538) Lasers, pulsed; (320.7090) Ultrafast lasers

1. Introduction

2 μm pulsed lasers with tens of gigahertz repetition rates are of increasing importance due to their potential applications in high-capacity telecommunication, optical interconnection and remote sensing [1, 2]. High repetition-rate pulsed lasers can be realized through extra-cavity modulation and via active mode-locking techniques. With extra-cavity modulation technique, 6 and 18 GHz repetition-rate sources at 2 μm were realized by spectrally masked phase modulation technique and time-lensing methods, respectively. However, the repetition rate of the 6 GHz source is rather low and the 18 GHz system exhibited relatively poor stability, low signal to noise ratio (SNR) and imperfect parabolic phase [4]. Active mode-locking techniques can be used to achieve high repetition pulsed laser source with ultrashort pulse widths and high signal SNR. Although tens of GHz have been obtained by this technique at a wavelength of 1.5 μm [5], the highest repetition rate laser at 2 μm by active mode-locking is limited to only 1.5 GHz [6, 7]. Highly stable actively mode-locked fiber laser operating with >10 GHz repetition rates remains to be demonstrated.

Here, we have developed a high repetition rate (up to 15 GHz), 2 μm all-fiber laser source via active mode-locking technique. The mode locking is realized by driving an intra-cavity lithium niobate phase modulator with modulation frequency equal to integral multiples of the cavity frequency. The demonstration of such a high repetition rate all-fiber laser paves the way for 2 μm high speed optical data processing, communications and metrology.

2. Experimental setup

The experimental setup is shown in Fig. 1. A continuous-wave 793 nm fiber laser served as the pump laser (BWT Inc.), and the pump light was launched into the ring cavity through a combiner. 4 m long single mode thulium doped fiber (TDF) with core/cladding diameter of 10/130 μm was used as the gain medium. Then, a polarization-sensitive lithium niobate phase modulator (LNPM, EOSPACE Inc.) driven by a RF signal were inserted in the cavity to perform actively harmonic phase modulation. The electro-optical bandwidth of the phase modulator is 20 GHz. The RF driving source (up to 40 GHz) was provided by a signal generator (KEYSIGHT N5183) and the signal was then amplified by a RF amplifier (SHF 81) to an output power of 24 dBm. To achieve maximum transmission of the phase modulator, we employed a polarization controller to control the polarization state of the incident light. Output pulses were extracted from a 30:70 optical coupler. With a pump power of 2 W and the output power was measured to be 20 mW. The total length of the ring cavity is about 21.29 m, corresponding to a FSR of $\Delta\nu = c/nL = 9.77$ MHz.

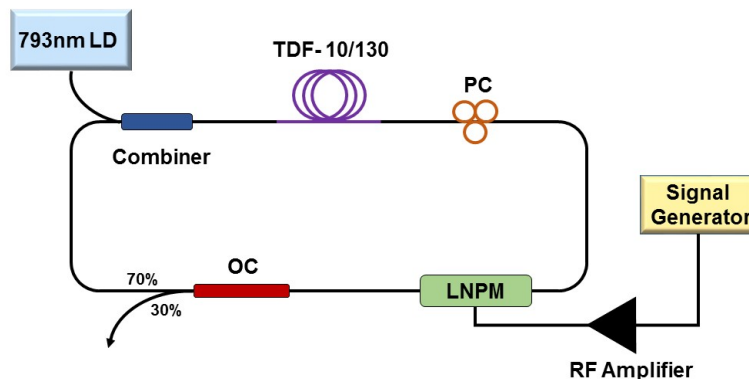

Fig.1 The schematic of the all-fiber active mode-locking system. LD: diode laser; TDF: thulium doped fiber; PC: polarization controller; LNPM: lithium niobate phase modulator; OC: optical coupler.

3. Results and discussion

Active mode-locking of the thulium fiber laser is achieved by modulating the phase modulator with different frequency which is integral multiple of the FSR. The output pulses were detected by a high-speed photodetector with a nominal bandwidth of 11 GHz (EOT ET-5000F), and then sampled by a 33 GHz real-time digital signal analyzer (KEYSIGHT MSOV334A). Output mode-locked pulse running at repetition rates of 9.77 MHz, 6 GHz, 9 GHz, and 15 GHz were shown in the Fig. 2(a~d), corresponding to the 1st, 614th, 923th, 1534th harmonic orders. In order to characterize the performance of the system, the extracted laser spectrum was monitored by an optical spectrum analyzer (Yokogawa AQ6375) with a resolution of 0.05 nm. Fig. 2(e) shows the spectrum of the mode-locked pulse, which is centered at 1981.6 nm with a 3 dB bandwidth of 0.77 nm. For the highest repetition rate of 15 GHz, the RF spectrum of the pulses were measured by RF spectrum analyzer with a RBW of 1k Hz in a scanning range of 300 MHz. A rather high signal to noise ratio of 66 dB indicates the good side-mode suppression in this operation regime. The advantage of this active mode-locking system is that the repetition rate can be easily controlled by modifying the driving electrical RF signals. We can obtain pulse trains flexibly tuned from ~ MHz to 15 GHz. The pulse shape exhibits a non-ideal sinusoidal shape at 15 GHz, which is probably due to the limited electrical bandwidth of the photodetector. Further experiments are now underway for measuring the pulse duration at such high repetition rate.

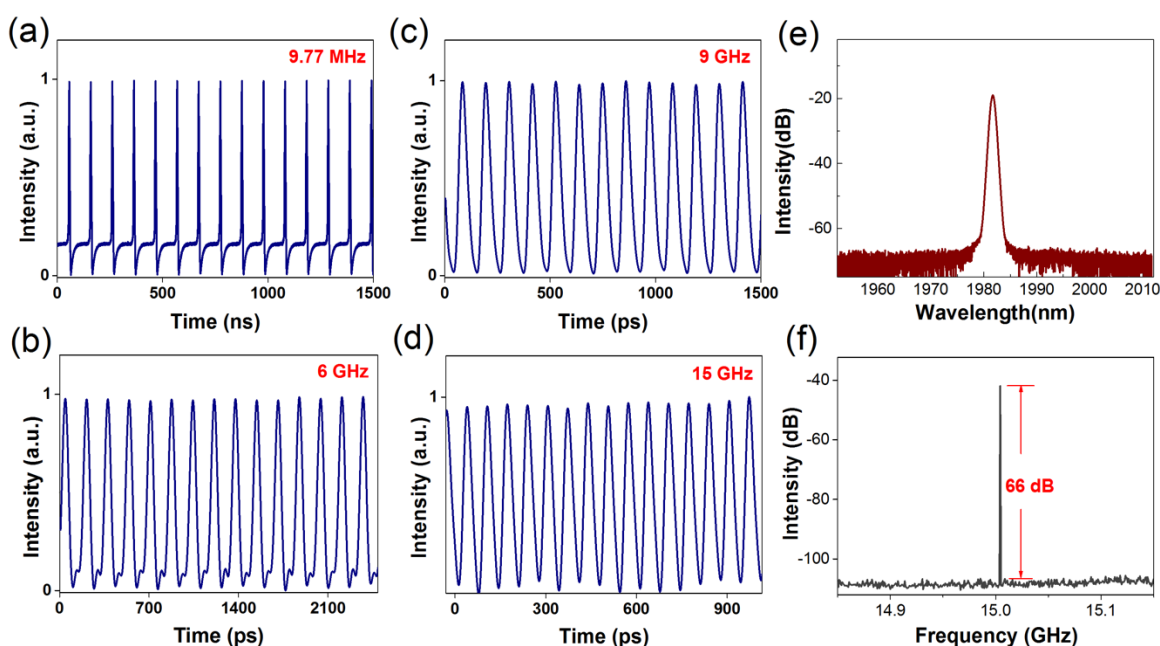

Fig.2 The mode-locked pulse trains observed by a digital signal analyzer, for (a) 1st, (b) 614th, (c) 923th and (d) 1534th harmonic orders; (e) Optical spectrum, (f) The RF spectrum over a span of 300 MHz, RBW=1k Hz.

4. Conclusion

In summary, through active mode-locking, we have demonstrated a thulium fiber laser operating at 15 GHz, which is the highest repetition rate that has been reported thus far. The repetition rate can be flexibly controlled from 9.77 MHz to 15 GHz, which shows great potential in high-speed 2 μ m data-communication and processing applications.

5. References

- [1] R. Soref, Nat. Photon. **9**, 358-359 (2015).
- [2] Y. Meng et al., Scientific Reports. **7**, 45109 (2017).
- [3] Qin, Jiarong et al., IEEE Photon. Tech. Lett. **29**, 2234-2237 (2017).
- [4] M. E. Durst et al., J. Lightwave Tech. **31**, 3714-3718 (2013).
- [5] R. S.Tucker et al., Electron. Lett. **25**, 621-622 (1989).
- [6] K. Yin et al., Opt. Lett. **39**, 4259-4262 (2014).
- [7] Wang, Xiong et al., IEEE Photon. J. **5**, 1502206-1502206 (2013).